



COMPACT SERIES

4DA20C, 4DA25C and 4DA27C Lift Trucks



It is what happens when vision, engineering and technology come together to produce the most rugged and versatile lift trucks on the market



SMART LIFT TRUCKS DESIGNED TO ADAPT TO ANY INDUSTRY OR TERRAIN, AND BUILT WITH THE HEART OF A LION TO DELIVER A LIFETIME OF DEPENDABLE SERVICE

The **4DA20C**, **4DA25C** and **4DA27C** lift trucks by **Vallée** are fast becoming the gold standard in industries ranging from lumber to mining, as well as for aluminum smelter and port applications. These heavy-hitters pack a lifting capacity of 20,000 to 27,500 lb. that belies their compact size. And because they are the product of a forward-thinking manufacturer that does not believe brawn and brains in a lift truck are mutually exclusive, they are also rich in articulated four-wheel-drive technology and design features that render them among the most versatile and agile anywhere. As for durability, they are made in North America. Need we say more?

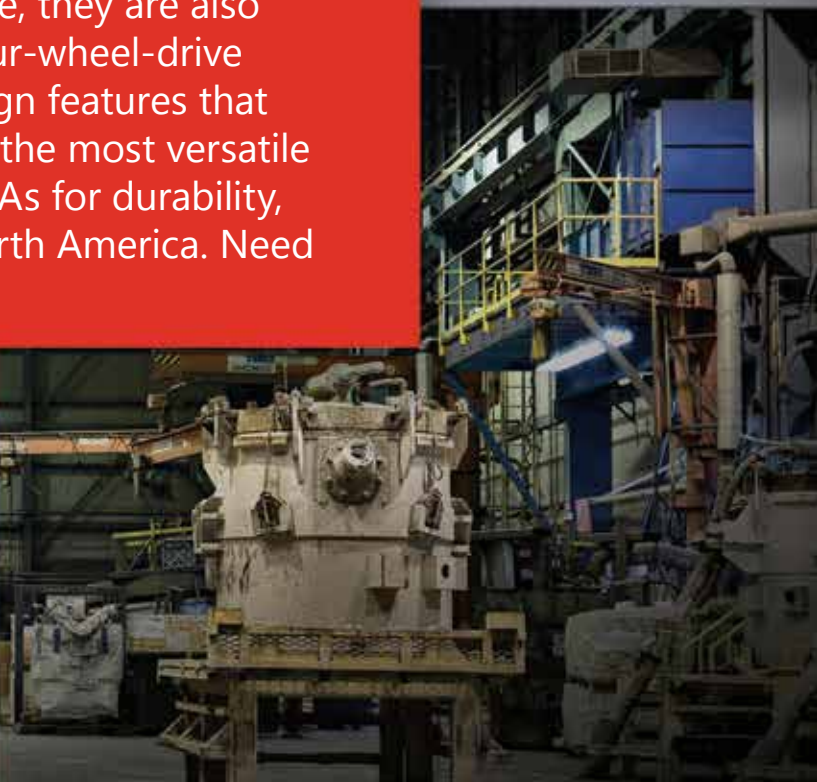
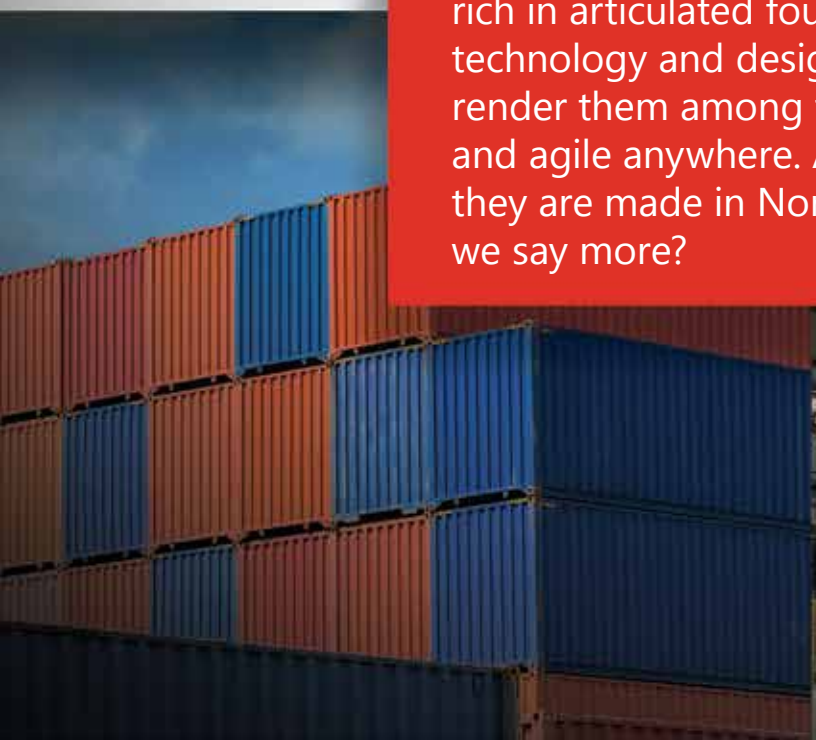

Vallée 4DA20C, 4DA25C and 4DA27C Lift Trucks

Compact Series Options



These lift trucks boldly go where no standard lift trucks can. Their compact size and articulated features make them ideal for squeezing into tight and confined spaces. E.g. a 4DA20C handling a pallet of timber 12 feet wide by 4 feet long can operate in narrow 19-foot aisles.



The heavy-duty, high-visibility mast allows for safer operations as it provides an optimal view of the loads and forks, and the worksite as a whole.

SOME OF THE TOP REASONS WHY THESE LIFT TRUCKS ARE SO ROBUST, AGILE AND COMFORTABLE

Some specifications

- Spacious full-view cab with minimal blind spots
- Narrower mast made with high-strength steel to increase visibility
- Compact sized but with the same capacity as larger lift trucks by other manufacturers
- Articulated for more agile operation
- Pilot-operated hydraulic controls for more accurate and flexible functional adjustments
- 6-speed transmission for better acceleration
- Tilt engine hood and cab for ease of service

MORE FEATURES:

Cummins QSB 4.5 Tier 3 Engine

This engine uses advanced technology to deliver improved performance and efficiency.

- More power
- Maximum reliability
- Constant nominal torque
- Constant low-end torque
- Reduced fuel consumption
- Increased acceleration response time
- Good cold weather start
- Engine warranty

Funk Transmission

The completely assisted gearshift is designed for increased productivity and performance and can be adapted to each load with precision. With our 6-speed automatic transmission and four reverse gears, the time-performance ratio and fuel consumption are totally optimized.

- Increased tractive force
- Optimal progress

AxleTech Axles

These heavy-duty axles are specifically designed to perform in extremely tough conditions and with heavy loads. They are exceptionally durable.

Wet-Disk Brakes

The components on these brakes are sealed for safer braking, lower operating costs, and unparalleled service life.

Hoist Cylinders

The cylinders are now located behind the fixed sections of the forklift to increase operator visibility.



The cab interior is wide, long and tall to give the operator more space and a comfortable ride. It also includes ergonomic controls, a multifunction suspension seat and an optional colour display monitor.



The full-view cab is equipped with an overhead window and is devoid of channels in rear corners to eliminate blind spots and increase all-around and upward visibility.



The engine hood opens mechanically, and can be tilted, along with the cab, for ease of service.*

*Although the engine shown here for illustrative purposes is a Tier 4 model, Compact Series lift trucks come with a Tier 3 engine.

WHAT A DIFFERENCE A NAME MAKES Vallée versus the competition

VISIBILITY

Because operator visibility tops the wish list of most lift truck buyers, we put unobstructed overhead and all-around views, and high visibility masts, at the top of our list. This includes a clear line of sight all the way to the tip of 4-foot forks.

ROBUSTNESS

Unmatched performance and reliability creating the highest level of uptime and production for our customers.

AGILITY

Articulated for better maneuverability and to squeeze into spaces too tight for other manufacturers' lift trucks, the 4DA20C, 4DA25C and 4DA27C are as operator and condition responsive as it gets.

CUSTOMIZATION

Our ability to custom design and build lift trucks as per your specific capacity and application needs is Vallée's undisputed trademark.

Vallée 4DA20C, 4DA25C and 4DA27C Lift Trucks

Compact Series Options

Technical specifications for 4DA20C, 4DA25C and 4DA27C Lift Trucks

COMPACT SERIES OPTIONS

- Double rear tires (standard for 4DA27C)
- Automatic lubricating system
- Marker beacon to signal distance
- Fire prevention system
- Customized transmission programming
- Compressor and compressed air outlet
- Hoist hook
- Air conditioner
- Color display screen
- Luxury suspension seat
- Boom suspension
- Compressor and compressed air outlet
- Hoist hook
- Air conditioner
- Color display screen
- Luxury suspension seat
- Boom suspension
- Oversized mast
- Full free-lift and semi free-lift mast
- Side shift
- Fork heel locks
- Removable or fixed back rack
- Multi-forks
- Underload positioner
- Levelling mechanism
- Camera guidance system
- Signal lights and brake lights
- Fleet manager system
- Remote control
- Alarm system
- Load scale



Levelling

This feature, which is rarely seen on the market, enables you to shift the fork carriage side to side by 5 degrees, to facilitate loading and unloading operations on uneven surfaces.



Side shift

This mechanism allows the operator to move the fork carriage laterally an extra 200 mm (8 inches) to the left or right, thus allowing you to deposit a load without having to re-manuever the entire lift truck into position.



Camera guidance system

Designed to perform in the most extreme mobile machine environments, this camera system offers three different display options to assist with visibility, including the area behind the truck and on the forks.



Luxury air suspension seat

Built to deliver optimal comfort during long operating hours, this seat combines high-density foam and a special membrane that diffuse pressure points and reduce muscle fatigue when seated for extended periods of time.

LIFT TRUCK ACCESSORIES



Snow plow

Uniquely shaped and built to instantly convert your lift truck for snow removal operations.



High dump bucket

3 to 18 cu. yd.-capacity hydraulic-actuated bucket designed to allow for higher dump height and built tough for light material or all-purpose use.



Tire handler

Delivers precision controlled tire lifting with a capacity of 10,000 lb.



Cable reeler

Powered by high-torque low-speed engines for more controlled traction, it also comes with quick coupling or direct pin mounting options.



Manipulating and reeling system for cables

Equipped with a motorized reeling system featuring speed control to facilitate winding and unwinding.



Custom solutions

We specialize in sizing up what our customers need and then setting out to tailor their equipment according to their specific requirements.

	Description	Units	VALLÉE 4DA20C	VALLÉE 4DA25C	VALLÉE 4DA27C	
Specifications	Capacity (load/distance)	lb./in. (kg/mm)	20,000/24 (9,071/610)	25,000/24 (11,339/610)	27,500/24 (12,473/610)	
	Lift height	in. (mm)	168 (4,267)	168 (4,267)	168 (4,267)	
	Mast tilt angle (F/R)	degrees	12/12	12/12	12/12	
	Overall length	in. (mm)	176 ^{3/4} (4,490)	179 ^{1/2} (4,560)	188 ^{3/8} (4,785)	
	Wheelbase	in. (mm)	100 (2,540)	100 (2,540)	100 (2,540)	
	Overall width	in. (mm)	98 ^{1/2} (2,509)	98 ^{1/2} (2,509)	98 ^{1/2} (2,509)	
	Overall height	in. (mm)	136 ^{3/8} (3,464)	140 (3,556)	140 (3,556)	
	Turning radius (exterior)	in. (mm)	193 (4,902)	193 (4,902)	193 (4,902)	
	Turning radius (interior)	in. (mm)	83 ^{1/2} (2,121)	83 ^{1/2} (2,121)	83 ^{1/2} (2,121)	
	Unloaded weight	lb. (kg)	35,775 (16,227)	40,900 (18,551)	43,275 (19,629)	
	Weight on front axle (laden)	lb. (kg)	47,800 (21,681)	58,400 (26,489)	61,100 (27,714)	
	Weight on front axle (unladen)	lb. (kg)	16,000 (7,257)	17,100 (7,756)	15,800 (7,166)	
Engine and transmission	Weight on rear axle (laden)	lb. (kg)	8,100 (3,674)	7,500 (3,401)	9,700 (4,399)	
	Weight on rear axle (unladen)	lb. (kg)	19,900 (9,026)	23,800 (10,795)	27,600 (12,519)	
	Number of tires (F/R)		4/2	4/4	4/4	
	Tire size		10-20,000	10-20,000	10-20,000	
	Engine (manufacture/model)		Cummins QSB 4.5 Tier 3	Cummins QSB 4.5 Tier 3	Cummins QSB 4.5 Tier 3	
	Engine (output)	hp. (kW)	148 (110)	148 (110)	148 (110)	
	Transmission (manufacture/type)		Funk (DF 150)	Funk (DF 150)	Funk (DF 150)	
	Number of gears (forward/reverse)		6/4	6/4	6/4	
	Performance	Top speed	km/h	28	28	28
		Gradeability (laden)	%	30	23	21
		Gradeability (unladen)	%	50	42	39
		Lifting speed (laden)	ft./s (mm/s)	1.4 (426)	1.1 (335)	1.1 (335)

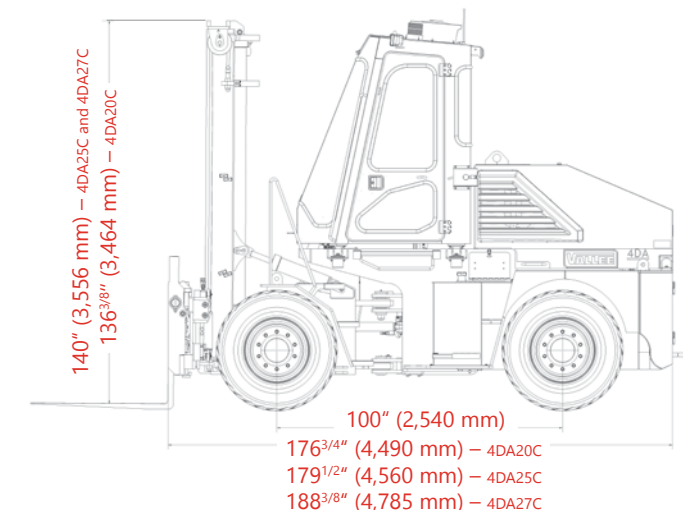
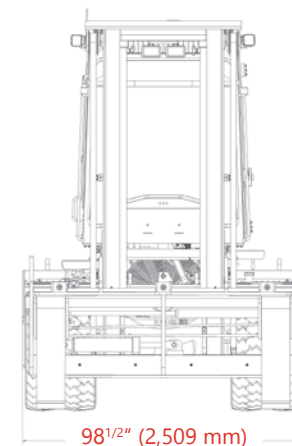



Founded in 1956, Vallée is the only designer and manufacturer of large capacity articulated four-wheel lift trucks and industrial equipment in Canada. We are proud of our "Made in Canada" products and their quality, dependability and performance.

Our trademark is customizing products to the specific needs of our clients. Because we are committed to crafting equipment of the utmost quality, we can guarantee our clients they are using the sturdiest, most durable products, which has earned us their unflinching trust over the years.

Just how exceptionally durable are Vallée lift trucks? More than 95% of the lift trucks we've sold are still in use.

Vallée products have been serving the Canadian and U.S. markets for over 20 years.

