



COMPACT SERIES

4DA20D XRT & 4DA25D XRT OTR Tire Lift Trucks



Vallée 4DA20D XRT and 4DA25D XRT Lift Trucks

Vallée Compact Series Options



The 4DA20D XRT and 4DA25D XRT are the vertical mast lift trucks that deliver the highest ground clearance on the market.

Combining robustness, visibility, agility and comfort, the 4DA20D XRT and 4DA25D XRT lift trucks are specifically built for rough terrain. Better still, XRT stands for “extra rough terrain.”

With a capacity starting at 20,000 lb. (9 metric tons) at 24 in. (610 mm) load centre, these lift trucks are ideal for handling loads on uneven surfaces or in tight spaces.

All models from Vallée’s XRT series can be tailored to your needs.

Some specifications

- Four-wheel-drive articulated lift truck
- 20,000 lb. (9 metric tons) capacity at 24 in. (610 mm) load centre to 25,000 lb. (11 metric tons) capacity at 24 in. (609 mm) load centre
- 5 in. (127 mm) clearance between tire and fender
- Hydraulic power steering
- Full-view cab with overhead window
- Extended cab
- Integrated monitoring system covering the vehicle’s 16 most important functions
- Heavy-duty mast and carriage
- Independent fork positioner
- High-visibility mast

Specifications Vallée 4DA20D XRT and 4DA25D XRT



Cummins QSB 6.7 Tier 4 Engine

Using advanced technology, such as a cooled exhaust gas recirculation (EGR) system and a variable geometry turbocharger (VGT), this engine delivers improved performance and efficiency.

- More power
- Maximum reliability
- Constant nominal torque
- Constant low-end torque
- Reduced fuel consumption
- Increased acceleration response time
- Good cold weather start



Funk Transmission

The completely assisted gearshift is designed for increased productivity and performance and can be adapted to each load with precision. With seven forward speeds and four reverse gears, the time-performance ratio and fuel consumption are totally optimized.

- Increased tractive force
- Optimal progress



The truck articulation and mast tilt give the operator superior freedom and flexibility.

EASY MAINTENANCE

We know how essential it is to minimize equipment downtimes and keep them running and producing instead. Which is why we incorporated a full-tilt hood and cab into the design, to render the parts instantly accessible. The result is an effective — and a measurably shorter — maintenance process.



COMFORT

Because this truck is built to put in long hours in rough conditions, we made sure comfort was an integral part of the design. The extended cab provides a roomier work environment. It comes standard with an ergonomic air suspension seat. Also, although the truck is fairly compact overall, we nevertheless conceived the wheelbase long enough to deliver superior stability, and by extension, better comfort.



Specifications Vallée 4DA20D XRT and 4DA25D XRT



Ergonomic Cab

- The cab is wide, long and tall to give the operator more space
- The front and rear window shafts have been removed to eliminate blind spots and increase all-around visibility
- The overhead window allows the operator to see the load as it is being lifted
- A rearview camera with colour screen increases visibility when operating the truck in reverse
- The improved ventilation system features strategically placed air vents to provide the operator with a more comfortable work environment
- The 7-function joystick is more comfortable and precise than hydraulic control levers
- Thanks to the now-standard colour display monitor, the operator can ensure that the vehicle is working properly by monitoring several functional parameters

AxleTech Axles

These heavy-duty axles are specifically designed to perform in extremely tough conditions and with heavy loads. They are exceptionally durable.

Wet-Disk Brakes

The components on these brakes are sealed for safer braking, lower operating costs, and unparalleled service life.

Hoist Cylinders

The cylinders are now located behind the fixed sections of the forklift to increase operator visibility.

Technical specifications 4DA20D XRT and 4DA25D XRT Lift Trucks

	Description	Units	VALLÉE 4DA20D XRT	VALLÉE 4DA25D XRT
Specifications	Capacity (load/distance)	lb./in. (kg/mm)	20,000/24 (9,071/610)	25,000/24 (11,340/610)
	Lift height	in. (mm)	197 (5,000)	197 (5,000)
	GVW (gross vehicle weight)	lb. (kg)	49,300 (22,370)	52,800 (23,950)
	Mast tilt angle (F/R)	degrees	13/18	13/18
	Overall length	in. (mm)	228 (5,791)	230 (5,842)
	Wheelbase	in. (mm)	130 (3,302)	130 (3,302)
	Overall width	in. (mm)	100 (2,540)	100 (2,540)
	Overall height	in. (mm)	153 (3,886)	153 (3,886)
	Number of tires (F/R)		2/2	2/2
	Tire size		23-5R25	23-5R25
Engine and transmission	Engine (manufacture/model)		Cummins QSB 6.7 Tier 4	Cummins QSB 6.7 Tier 4
	Engine (output)	hp. (kW)	172 (128)	172 (128)
	Transmission (manufacture/type)		Funk (DF 150)	Funk (DF 150)
	Number of gears (forward/reverse)		7/4	7/4
Performance	Top speed	km/h	39	39
	Gradeability (laden)	%	34	34
	Gradeability (unladen)	%	55	55
	Lifting speed (laden)	ft./s (mm/s)	1.4 (427)	1.1 (335)

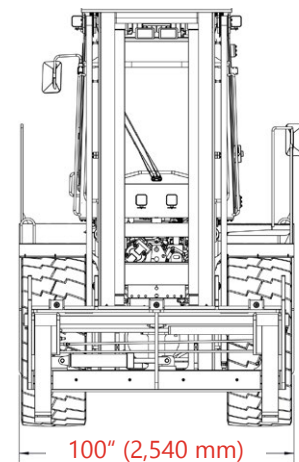
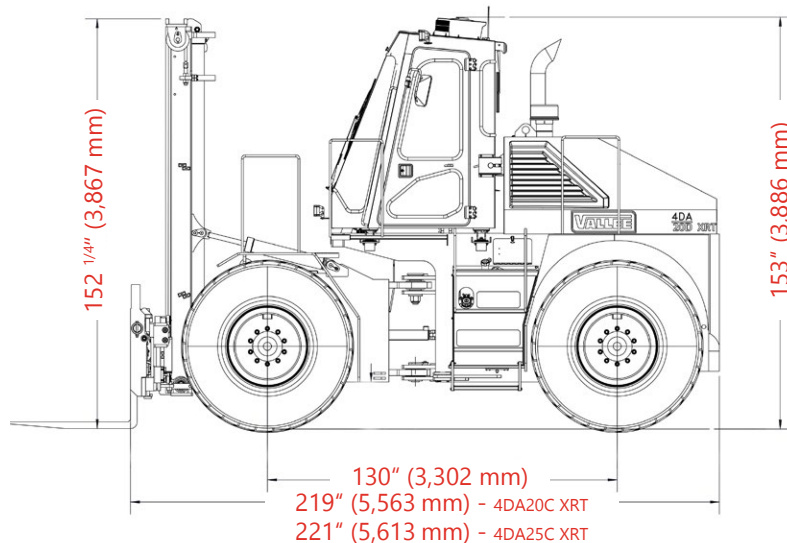

CHA_XRT_2016-01-25_V1_EN_C

