

HANDLING EQUIPMENT

INNOVATIVE AND CUSTOMIZED HANDLING SOLUTIONS

At Vallée, we live and breathe heavy-duty equipment. For over 60 years, we've carved a reputation in the industry as a key provider of handling solutions, capable of delivering "the" solution that best fits your needs, regardless of their size or scope.

We design and manufacture a wide range of equipment for your handling operations. Our forks, buckets and tools are built to adapt to your loaders, lift trucks and excavators. We always strive to innovate to help you improve your productivity and safety. We know and do what it takes to optimize your operations, and our turnarounds are unbeatable. Because your satisfaction is always paramount.



Side Dump Bucket

- Side dump bucket with hydraulic actuated left or right unloading
- Capacity of 4 to 10 cu. yd. (3.1 to 7.7 m³)
- Quick hook or direct pin mounting available for all equipment brands
- Reversible bolt-on wear blades



Loader Lift Truck



High Dump Bucket

- Hydraulic actuated high dump bucket
- Capacity of 3 to 18 cu. yd. (2.3 to 13.7 m³)
- Width: 8.4 to 14 ft. (2.54 to 4.27 m)
- Built tough for light material or all purpose use
- Designed to allow for higher dump height
- Reversible bolt-on wear blades, in 4 sections
- Double hydraulic cylinders with cushioning
- Quick coupling or direct pin mounting available for all loader brands



Loader Lift Truck



All Purpose Bucket

- Capacity of 1 to 10 cu. yd. (0.7 to 7.6 m³)
- Heavy-duty bucket also available
- Quick coupling or direct pin mounting available for all loader brands
- Equipped with reversible bolt-on wear blades or ground engaging tools



Loader



Gravel Bucket

- Capacity of 1 to 10 cu. yd. (0.7 to 7.6 m³)
- Steel construction
- Quick coupling or direct pin mounting available for all loader brands
- Options:
 - Standard or heavy-duty construction
 - Bolt-on blades or ground engaging tools
 - Rock guard



Loader



Bucket for Light Materials

- Capacity of 1 to 26 cu. yd. (0.7 to 20 m³)
- Designed with view holes for better visibility
- Equipped with reversible bolt-on wear blades
- Quick coupling or direct pin mounting available for all loader brands



Loader



Quarry Bucket

- Capacity of 1 to 10 cu. yd. (0.7 to 7.6 m³)
- Steel construction
- Bucket with reversible bolt-on wear blades or with teeth
- Quick coupling or direct pin mounting available for all loader brands
- Options:
 - Straight lip or spade nose configuration
 - Heavy-duty or super heavy-duty construction
 - Rock guard



Loader



Sand Bucket

- Capacity of 4 to 7 cu. yd. (3 to 5.3 m³)
- Dispersion grooves make spreading easier
- Shaft casing supported by roller bearings located on the bucket's exterior
- Hydraulic motor
- Swivels in both directions without blowback into the tank
- Shaft and motor guard
- Bolt-on Teflon sections
- Removable for summer applications
- Quick coupling or direct pin mounting available for all loader brands

Go to <http://vallee.ca/en/produits/attachments/sand-bucket/> for a video of the Vallée Sand Bucket.



Loader



One-Way Snow Plow for Mining Applications

For slow-speed snow removal operations. Unique shape makes it ideal for projecting snow.

- Fits all wheel-loader models
- Bolt-on wear blades and skid shoes
- Available in various widths



Loader

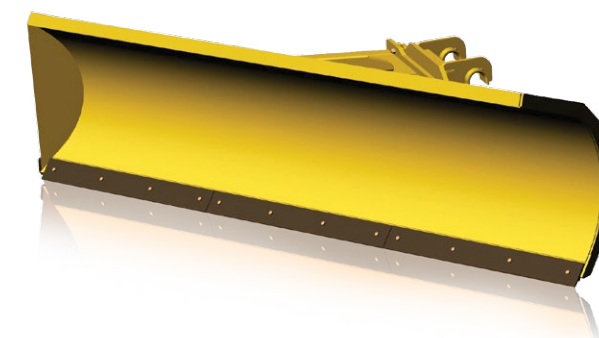

V Plow

- Available in widths of 5 to 14 ft. (1.5 m to 4.26 m), with or without side panels
- Shockproof safety valve
- Parking stand
- Skid shoes bolted on trip edges
- Suitable for all types of loaders
- 30° hydraulic positioning system
- Options:
 - Heavy-duty construction
 - 3 or 6 trip edge sections



Loader



Lift Truck

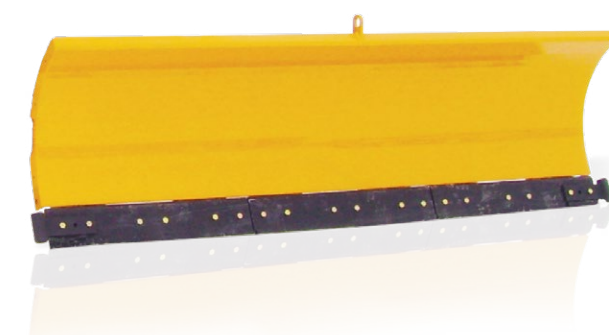

Sidewalk Snow Pusher

This small yet mighty Sidewalk Snow Pusher by Vallée is specifically designed for smaller multi-purpose municipal vehicles. Suitable for all brands and models.

- 30° hydraulic positioning system
- Single 5 ft. (1.5 m) twin spring-loaded trip edge
- Shockproof safety valve



Loader



Lift Truck

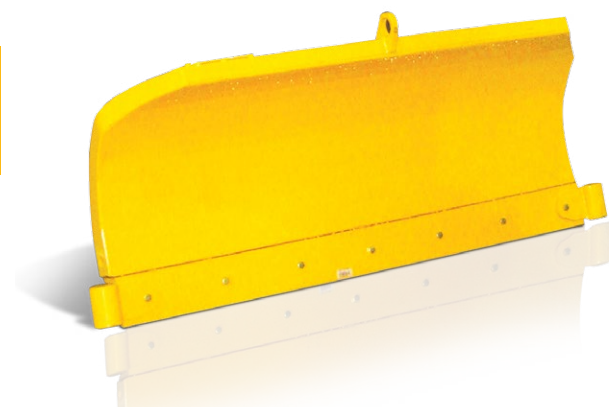

Wing Plow

The Vallée Wing Plow increases your loader's plowing efficiency during snow removal operations.

- Available in widths of 10, 11, 12, or 13 ft. (3, 3.4, 3.7 or 4 m)
- Equipped with a front column fitted with a 10 in. (24 cm) hydraulic cylinder
- Front suspension system
- Bolt-on blades, in two sections
- Two bolt-on skid shoes
- Parking stand
- Spring-loaded push arm in case of collisions
- Three-point rear connection system



Loader

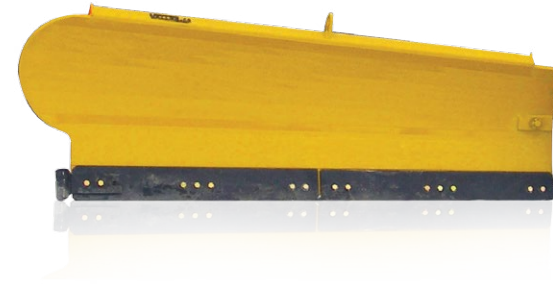

Snow Pusher

- Available in widths of 6 to 24 ft. (1.82 to 7.31 m)
- Bolt-on reversible wear blades made of steel
- Bolt-on side panel wear skates made of steel
- Bolt-on front corner skid shoes made of steel
- Interior (optional) and exterior hooks
- Built tough and adaptable
- Quick coupling or direct pin mounting available for all loader brands
- Options:
 - Heavy-duty construction
 - Backward blade available
 - Fork set available



Loader



Lift Truck



Ice Plow

- Perfect for clearing ice from your driveways and sidewalks
- Simple, rugged design
- Assorted widths available
- Bolt-on scraper blade
- Suitable for all types of loaders



Loader



Lift Truck



Plow With Hydraulic Endplates

- Available in widths of 6 to 24 ft. (1.82 to 7.31 m)
- Bolt-on reversible wear blades made of steel
- Bolt-on side panel wear skates made of steel
- Built tough and adaptable
- Quick coupling or direct pin mounting available for all loader brands
- Options:
 - Heavy-duty construction



Loader



Lift Truck

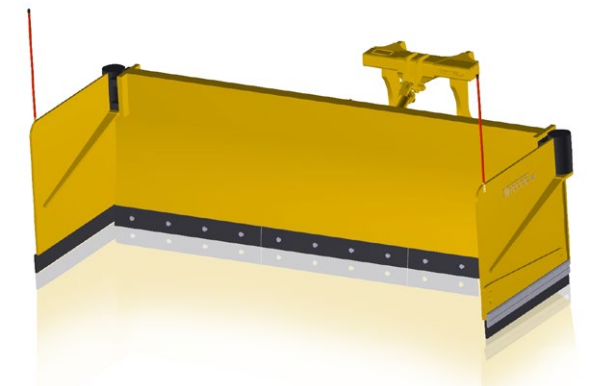

Expandable Plow

- Hook adapts to need, end-use
- Hydraulic pivoting system equipped with impact protection
- Bolt-on reversible blades with optional trip edge
- Bolt-on side panel reversible wear skates
- Bracing tube
- Expandable widths available based on loader and lift truck capacity



Loader



Lift Truck



Tire Handler

The Vallée Tire Handler is known for its ease of use, the broad visibility it provides the operator, and precise execution.

- 10,000 to 35,000 lb. capacity (4.6 to 15.8 tons)
- Handles tires with or without rims and chains
- Precision controlled tire lifting
- Proportional valves
- Broad visibility
- Made tough, durable
- Tire arm equipped with anti-tipping system
- Options:
 - Remote control

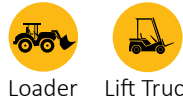

Loader Lift Truck

Quick Coupler

- Vallée Quick Couplers are strong, versatile and compatible with all models of loaders and hooks on the market
- Made sturdy, but weight is optimized so the effective capacity of the loader is never compromised
- Designed for broad visibility
- Options:
 - Manual or hydraulic lock

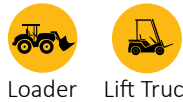

Loader Lift Truck

Handling Arm

- For loaders capable of handling 1 to 12 cu. yd. and lift trucks 5,000 lb. (2.3 tons) and up
- Available in various dimensions and capacities depending on your need
- Suitable for a variety of applications and industries, including construction, mining, pulp and paper
- Options:
 - Extendable manual or hydraulic arm



Loader Lift Truck



Blank Hook Set

Vallée offers the widest range of hooks on the market, and can also tailor the hooks to the vehicle upon request. Manufactured for Vallée equipment and the majority of other machinery on the market.



Loader Lift Truck



Mast

Vallée full-view masts feature greater lift capacity than traditional wheel-loader arms.

- Custom-made masts based on vehicle capacity
 - lift capacity of 5,000 to 55,000 lb. (2.3 to 25 metric tons)
- Custom fork carriages
- Lift based on specific requirements
- Options:
 - Semi and full-free lift
 - Fork leveling, side shifting, and positioning feature



Loader Lift Truck



Standard Forks

We carry a large selection of forged forks in a wide variety of dimensions so we can respond to our customers' needs immediately.

- Hook- and ring-type forks
- Fork-mounted carpet rams
- Bolt-on forks
- Forks for handling steel coils
- Rotating forks
- Fork extenders



Loader



Lift Truck



Custom Forks

We can custom manufacture forged forks for lift trucks regardless of the brand, model and size, including older vehicles that are still on the market!



Loader



Lift Truck



One-Piece or Fixed Fork Carriage

- Super heavy-duty construction with high-strength steel, ideal for quarry applications
- Equipped with superior quality forged forks
- Welded forks eliminate any shifting while work is being carried out (one-piece)
- Quick coupling or direct pin mounting available for all loader brands
- Options:
 - Fixed forks



Loader



Do you know when it's time to replace your forks?

Save time and work safely. Calculating the wear rate, remaining capacity and acceptable maximum capacity of your forks is easy with Vallée.

DO IT ONLINE AT **VALLEE.CA** AND RECEIVE A QUOTE FOR YOUR FORKS WITHIN 24 HOURS.

Evaluate the condition of your forged forks

Initial Capacity (per fork) lb.

Initial Thickness in.

Measured Thickness in.

Calculate

Wear Rate = 8.3%

Percentage of Remaining Capacity = 84.8%

Maximum Remaining Charge = 16 967 lb.
(per fork)

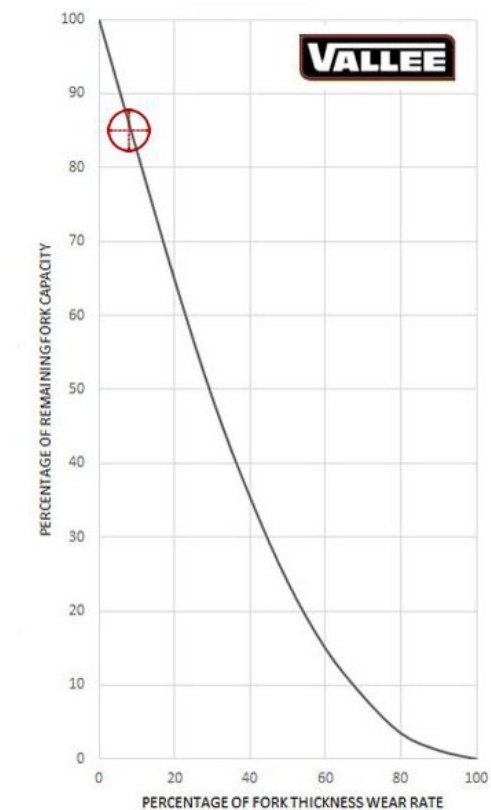

Fork Carriage

- Designed for strength and broad operator visibility
- Available in various dimensions for loaders with capacities of 1 to 6 cu. yd. (0.8 to 4.6 m³) and more
- Widths ranging from 4 to 12 ft. (1.2 to 3.7 m³)
- Equipped with superior quality forged forks
- Attachments for hook- or ring-type forks
- Quick coupling or direct pin mounting available for all loader brands
- Options:
 - Manual or hydraulic positioner
 - Hydraulic positioner with vertical movement
 - Side shifting
 - Lateral leveler
 - Package press
 - Back rack
 - Rotator



Loader

Loader

- Extended Fork Arm
- Built for strength and broad operator visibility
- Widths ranging from 14 to 50 ft. (4.3 to 15.2 m)
- Can be custom designed to meet customer requirements
- Equipped with superior quality forged forks
- Quick coupling or direct pin mounting available for all loader brands
- Options:
 - Can include 2 forks or more
 - Manual or hydraulic positioning system



Loader Lift Truck

Combined Grapple

Our combined grapples are perfect for feeding logs into sawmills and handling pallets of finished product.

- Full-view design
- Fork dimensions and widths customized to reflect requirement



Loader Lift Truck



Package Press

Fork package presses are optional add-ons. They help stabilize loads, e.g. loosely packed wood.

- Dimensions subject to requirements
- Fits virtually all fork carriages



Loader Lift Truck



Loading/ Unloading Grapple

- Hydraulic log ejector
- Hook or direct pin mounting grapples
- Interchangeable teeth
- Width customized based on log length
- Optimized loading/unloading geometry



Loader Lift Truck



Rail Car Attachment

- Enhances the versatility of your loader, i.e. use it to pull or push rail cars
- Side shift clip allows you to push even when the cars are not perfectly aligned
- Suitable for all types of loaders
- Standard width 4 ft. (1.2 m) – other widths also available upon request
- Options:
 - Manual or hydraulic locking
 - Free or hydraulic side shifting



Loader



Lift Truck



2-in-1 Manipulating and Reeling System for Mining Cables

- Motorized reeling featuring speed control for winding and unwinding
- Front arm makes it easy to wind cable onto the roller with control
- Two extendable side arms to safely move 7,000-volt shovel power cables, thus minimizing direct handling of cables to increase the safety of the ground crew
- Hydraulic hoist system to prevent overloading the arms
- Quick coupling or direct pin mounting available for all loader brands



Loader



Lift Truck



Cable Reeler

- Cable reeling powered by high-torque low-speed engines for more controlled traction
- Quick coupling or direct pin mounting available for all loader brands



Loader



Lift Truck



“POWERLOCK” Excavator Quick Coupler

The Powerlock Excavator Quick Coupler with minimal offset is powerful, reversible and interchangeable.

- The lower offset means the ripping power of your excavator is not compromised
- Secured at two points: two wedges compensate for wear and tear
- Reversible hooks, at no additional cost
- Compatible with all excavators, e.g. PC200 tools can be switched with EC210 tools
- Options:
 - Group 1: 15.4 lb. (7 tons) or less
 - Group 2: 15.4 to 30.8 lb. (7 to 14 tons)
 - Group 3: 30.8 to 46.2 lb. (14 to 21 tons)
 - Group 4: 46.2 to 72.7 lb. (21 to 33 tons)
 - Mechanical or hydraulic locking system



Excavator

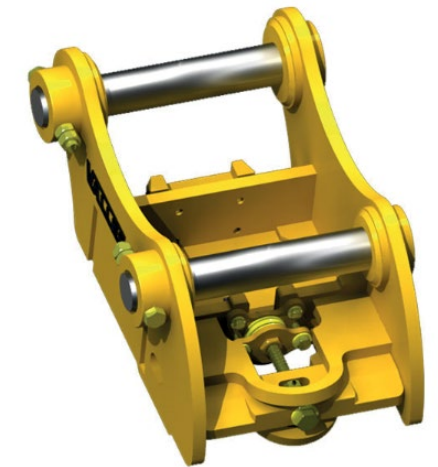

Hydraulic Thumb

This tool helps you grab and hold onto material that does not fit in your bucket.

- Different lengths and widths available, based on the bucket; or fitted with a quick coupling system
- Pivot with lubricators and hardened rings
- Hydraulic cylinder and connector included
- Options:
 - Available with 2 or 4 teeth



Excavator



Excavator Bucket

The shape of the Excavator Bucket is designed for deep soil penetration and efficient filling

- Available with all styles of ground engaging tools
- Made of high-strength steel
- Available in different widths and capacities, based on the excavator
- Hook or direct pin mounting
- Options:
 - Heavy-duty or super heavy-duty construction



Excavator

Skeleton Bucket

The Skeleton Bucket is ideal for removing stumps and shrubs, and for cleaning. Perfect for forestry, agriculture and other industries.

- Multiple tooth options (custom width and number)
- High-strength steel



Excavator

Ditch Cleaning Bucket, fixed or tilting Model

- For all excavators, according to their lift capacity
- Built with high-strength steel for long life and performance
- Width and capacity customized based on the excavator
- Hook or direct pin mounting



Excavator

Material Handling Bucket

- Like the Ditch Cleaning Bucket, the Material Handling Bucket is specially angled to facilitate truck loading operations
- Width and capacity customized based on the excavator
- Hook or direct pin mounting
- Options:
 - Wear blade also available

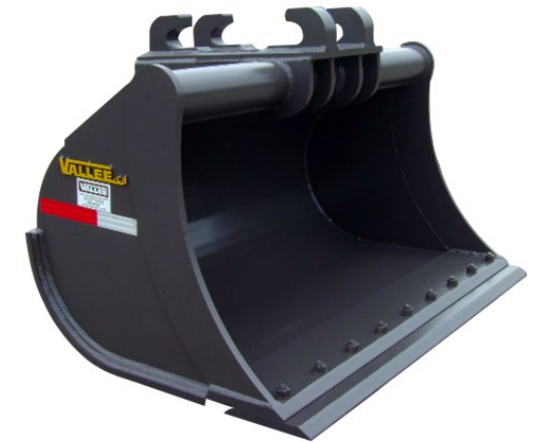

Excavator

Trapezoidal Bucket

- Ideal for digging sloped trenches without having to needlessly move your excavator
- Width and capacity customized based on the excavator
- Hook or direct pin mounting
- Options:
 - With or without teeth



Excavator

Ripper

This single-tooth tool has incredible ripping power and effortlessly scarifies frozen ground or rocky soil.

- Choice of interchangeable teeth
- Tooth length and thickness based on excavator's capabilities
- High-strength steel



Excavator



We get a handle on what our customers need and then set out to tailor their equipment accordingly. That's how we created our mine cable manipulator and our tire handler. Now you too can benefit from these innovations!

Mine Cable Manipulator

Following an injury to a worker, a mining company called on Vallée's engineers and designers to create and produce an arm that could safely pick up and move 7,000-volt shovel power cables without any ground personnel. In less than six weeks, we designed and built the mine cable manipulator, which later won a prize for innovation from the CSST workers compensation board.



Spécifications :

- 16 ft. (4.8 m) reach • 120° clearance (60°+ 60°) • 8,000 lb. (3.6 tons) lift capacity • Rugged hydraulic arm • Articulated claw equipped with sturdy tip to hoist cables • Rollers made of self-lubricating molybdenum disulfide (6PA MoS2)
- Cable rigging mechanism easy to operate from a loader or lift truck • Cable holder fitted with non-conducting, self-lubricating nylon rollers to minimize cable wear and tear caused by frequent handling

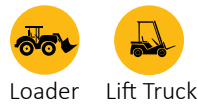

Double Bucket System

A client asked us to create a double bucket system for tree planting purposes, that would allow them to dig two holes simultaneously, thus doubling productivity. Vallée rose to the challenge and built a heavy-duty double bucket for excavators. Each bucket can handle up to 0.82 cu. yd. (0.75 m³) (under SAE Standard J742) and is 2 ft. (61 cm) wide, yielding an overall width of 11 ft. (3.35 m).



Excavator

Lifting Anchor

We were commissioned to create a tool capable of transporting a loader, among other heavy machinery, inside a ship. Our engineering team designed a lifting anchor that can be screwed onto a loader's frame and secured to the roof. A ring on the anchor allows the vehicle to be crane lifted onto the ship. For dock use.



Features:

The anchor is 10 ft. (3 m) long and can lift up to 50,000 lb. (22,680 kg).



Sieve Bucket

A customer was looking to optimize their concrete waste sorting operations. Vallée designed a sieve bucket that now enables them to perform three functions with the same tool: load, sift and unload.

Features:

- Designed to sift a wide range of materials, including concrete
- Capacity calculated as per SAE Standard J742
- Sieve openings adjusted to your requirements
- Equipped with reversible bolt-on wear blades or ground engaging tools
- Also available with heavy-duty bucket
- Capacity of 1 to 5 cu. yd. (0.7 to 3.8 m³)
- Quick coupling or direct pin mounting available for all loader brands



Loader Excavator

VALLEE

HANDLING EQUIPMENT

INNOVATIVE AND CUSTOMIZED HANDLING SOLUTIONS

Productivity and safety are critical factors for industries where materials handling is a quintessential part of their operations. You can count on our expert R&D team to get to the root of where your operations should be optimized, in order to design solutions firmly tailored to what you do and what you need.

